

AMCC-8

NOTES:-

- 1.) CUSTOMER TO MARK THE DIMENSIONS/CHARACTERISTICS THAT ARE CRITICAL TO FIT/FORM AND FUNCTION ON THE DRAWING.
- 2.) NUMBER OF COMPONENTS TO BE SUBMITTED FOR PILOT PRODUCTION LOT=_____PIECES.
- 3.) UNLESS OTHERWISE SPECIFIED, STANDARD PACKAGING USED BY HITACHI METGLAS WILL BE PROVIDED.
- 4.) ALL PRODUCTION RECORDS AND DATA PERTAINING TO THIS PRODUCT WILL BE RETAINED FOR A PERIOD OF 1 YEAR FROM THE DATE OF SHIPMENT.

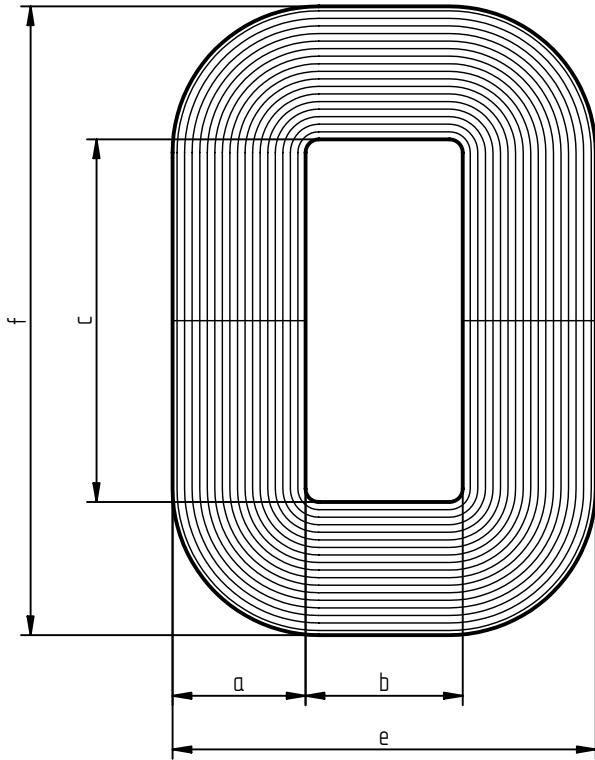

PHYSICAL SPECIFICATIONS

Core Build	(a) mm	11.0±0.8
Window Width	(b) mm	13.0+1.0/-0.0
Window Length	(c) mm	30.0+2.0/-0.0
Core Height	(d) mm	20.0+0.5/-0.0
Core Width	(e) mm	35.0+1.0/-0.5
Core Length	(f) mm	52.0+2.0/-0.0
Mean Magnetic Path	(l_m) cm	13.20
Net Area	(A_c) cm ²	1.80
Window Area	(W_a) cm ²	3.90
Area Product	(A_p) cm ⁴	7.00
Weight of Core	g	170 (Nom.)

ELECTRICAL SPECIFICATIONS

Core Loss @ 16kHz, 0.037 T \leq 1.38W/Kg.

l_m = mean magnetic path length

A_c = net cross-sectional area

W_a = core window area

NOTE :-

1. ALL MEASUREMENTS ARE DONE AT ROOM TEMPERATURE.
2. WEIGHT INCLUDES 2% EPOXY WEIGHT.
3. CONTINUOUS OPERATING TEMPERATURE : 155°C

CORE MATERIAL: MEGLAS® ALLOY 2605SA1

NOTE :-
THIS DRAWING, THE PROPERTY OF HITACHI METGLAS INDIA PVT. LTD. IS FURNISHED SUBJECT TO RETURN ON DEMAND AND THE CONDITION THAT THE INFORMATION AND TECHNOLOGY EMBODIED HEREIN SHALL NOT BE DISCLOSED OR USED AND THE DRAWING SHALL NOT BE REPRODUCED OR COPIED IN WHOLE OR IN PART EXCEPT AS PREVIOUSLY AUTHORIZED IN WRITING. ANY PERSON WHO MAY RECEIVE OR OBSERVE THIS DESIGN WILL BE HELD STRICTLY LIABLE FOR ANY VIOLATION WHETHER WILLFUL OR NEGLIGENT.

TOLERANCES UNLESS OTHERWISE SPECIFIED	NO.	REVISION	BY	APPR.	DATE	DIMENSIONS	MM	DESCRIPTION	SHEET NO.	DRAWING NO.	REV. NO.												
	1.)	CORE LOSS WAS WRITTEN MEASURED @ 0.37T BY MISTAKE, INSTEAD OF 0.037T		SR	04/19/02	SCALE	N.T.S	C-CORE DESIGN	1 OF 1	AMCC-8	4												
	2.)	COMPANY NAME WAS HONEYWELL.	SA	RK	02/14/04	PROJECTION	THIRD ANGLE	MATERIAL AS NOTED															
	3.)	ADDED NOTE#3. (AS PER PCN002).	SA	RK	07/26/04	<div style="text-align: center;"> HITACHI METGLAS </div> <table border="1" style="width: 100%; border-collapse: collapse;"> <tr> <td>SR</td> <td>07/12/01</td> <td>SR</td> <td>07/12/01</td> <td>RH, RM, ST</td> <td>07/19/01</td> </tr> <tr> <td>DRAWN</td> <td>DATE</td> <td>CHECKED</td> <td>DATE</td> <td>APPROVED</td> <td>DATE</td> </tr> </table>						SR	07/12/01	SR	07/12/01	RH, RM, ST	07/19/01	DRAWN	DATE	CHECKED	DATE	APPROVED	DATE
SR	07/12/01	SR	07/12/01	RH, RM, ST	07/19/01																		
DRAWN	DATE	CHECKED	DATE	APPROVED	DATE																		
	4.)	PRODUCT & DRAWING FORMAT REVISED. (AS PER PCN004)	RG	RK	25/09/06																		